

modello **Airone**
e Pagoda

in acciaio zincato
galvanized steel





modello
Airone





Sezione dei profili utilizzati per il modello Airone Section of the utilized profiles for the model Airone

Sezione del montante
Section of the vertical pillar

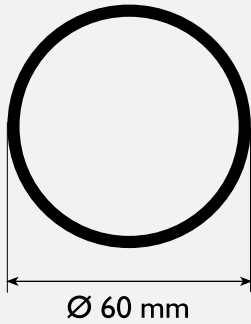

Sezione della barra perimetrale
Section of the perimetrial beam

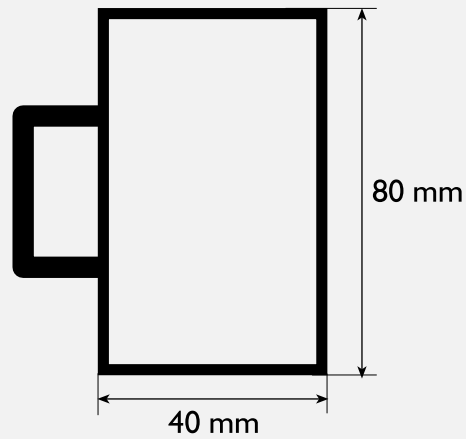

Sezione del puntone inclinato
Section of the inclined bar

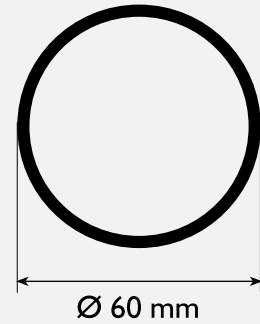

Componenti principali della struttura Principal elements of the structure



Cupolino coprisfiato
Air-outlet top-cup

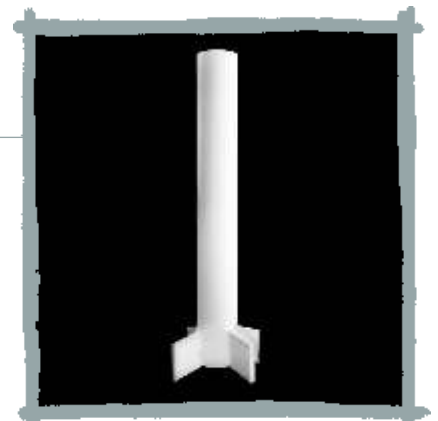
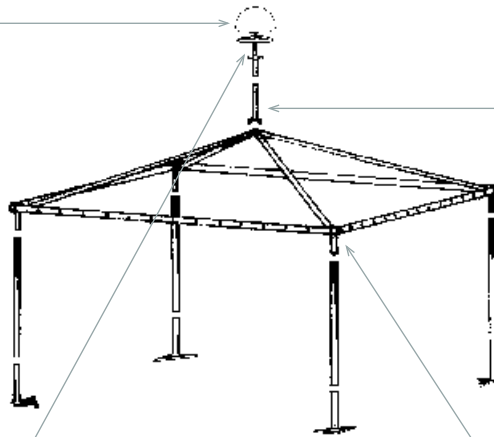

Puntone centrale
Central support



Piatto tenditelo
Fabric lifting rafter



Piede
Foot





Innesto angolare
Angular joint

mod. **Airone** (in acciaio zincato / galvanized steel)



con struttura in acciaio zincato o zincato-verniciato*, telo di copertura in PVC ignifugo e cupolino coprisfiato modello I.
with galvanized steel frame or powder coated galvanized steel frame, fire-retardant PVC cover and air-outlet top cup type I.

AIRONE quadrato / Squared AIRONE

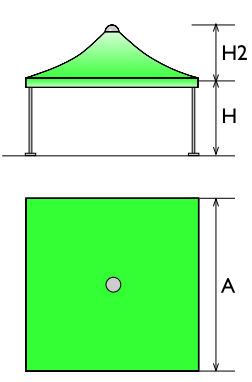
A	H	H2	 $\simeq m^2$	Massima lunghezza maximal metrical	 $\simeq m^3$	 $\simeq Kg$	n° colli # pieces
m 3.00	2.28	1.15	9.00	2.98	0.27	139	8
m 4.00	2.28	1.44	16.00	3.98	0.28	172	8
m 4.90	2.28	1.72	24.00	4.88	0.29	202	8
m 6.00	2.28	1.82	36.00	5.98	0.30	282	10



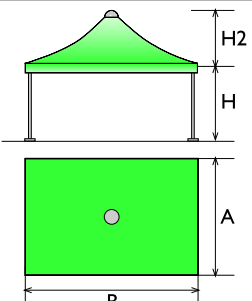

AIRONE rettangolare / rectangular AIRONE

A - B	H	H2	 $\simeq m^2$	Massima lunghezza maximal metrical	 $\simeq m^3$	 $\simeq Kg$	n° colli # pieces
m 3.00 x m 4.00	2.28	1.35	12.00	2.98	0.29	180	10
m 4.00 x m 5.00	2.28	1.55	20.00	3.98	0.31	231	10
m 5.00 x m 6.00	2.28	1.75	30.00	4.88	0.33	272	10



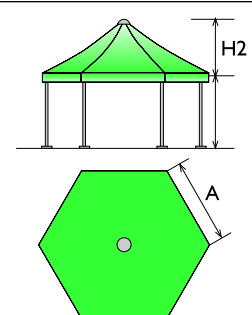

AIRONE esagonale / hexagonal AIRONE

A	H	H2	 $\simeq m^2$	Massima lunghezza maximal metrical	 $\simeq m^3$	 $\simeq Kg$	n° colli # pieces
m 3.00	2.28	1.70	23.38	2.98	0.32	225	11
m 4.00	2.28	2.20	43.67	3.98	0.34	281	11
m 4.90	2.28	2.70	62.38	4.88	0.36	336	11



AIRONE ottagonale / octagonal AIRONE

A	H	H2	 $\simeq m^2$	Massima lunghezza maximal metrical	 $\simeq m^3$	 $\simeq Kg$	n° colli # pieces
m 3.00	2.28	1.90	43.45	3.70	0.36	291	15
m 4.00	2.28	2.70	81.16	5.07	0.39	360	15

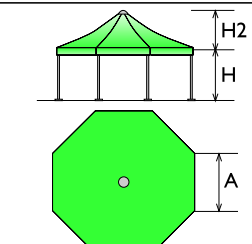

Schema di montaggio del modello Airone

Assembling plan for the model Airone

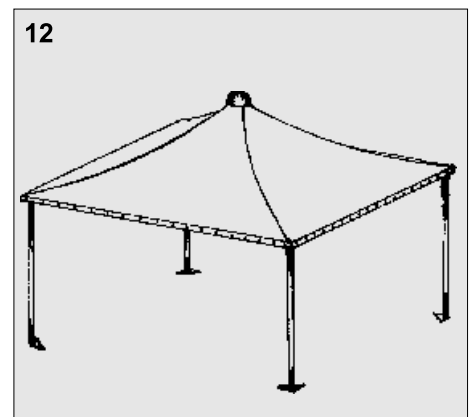
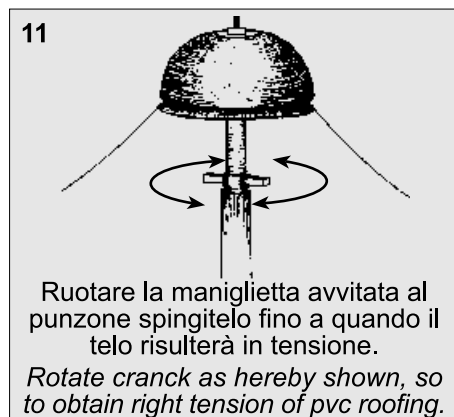
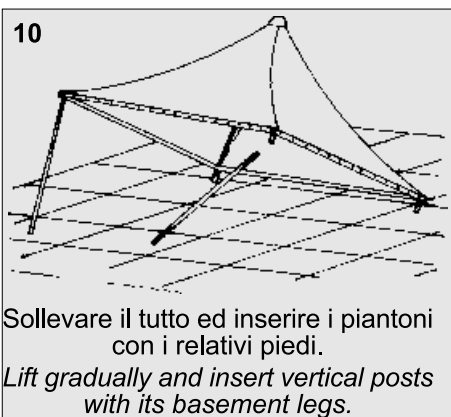
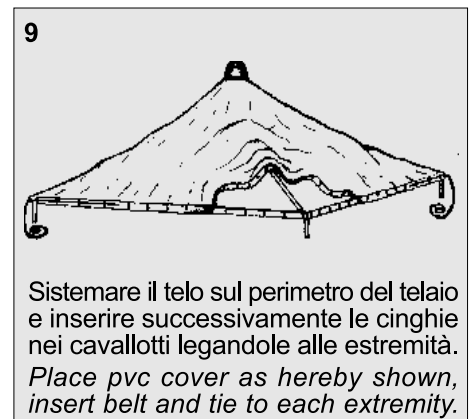
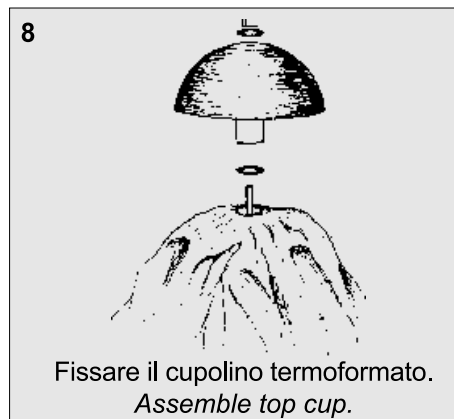
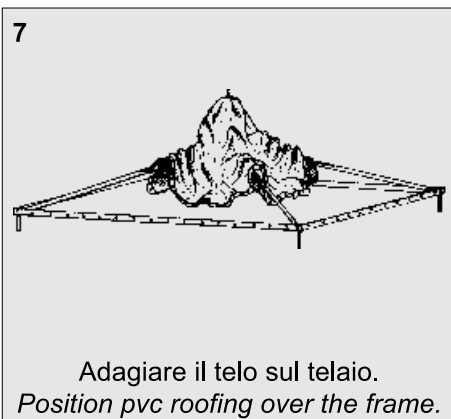
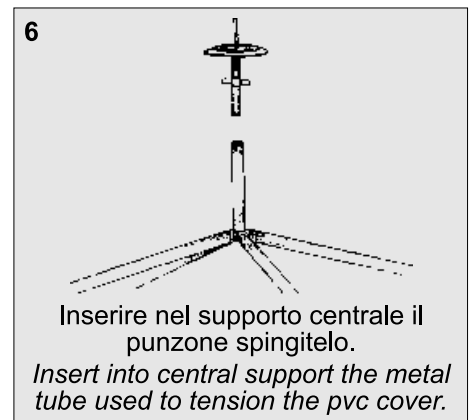
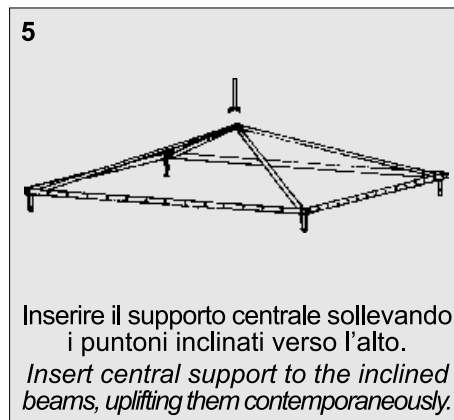
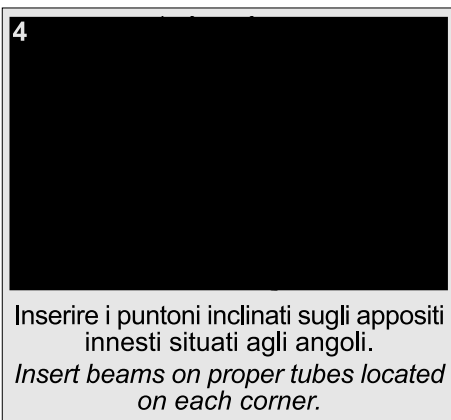
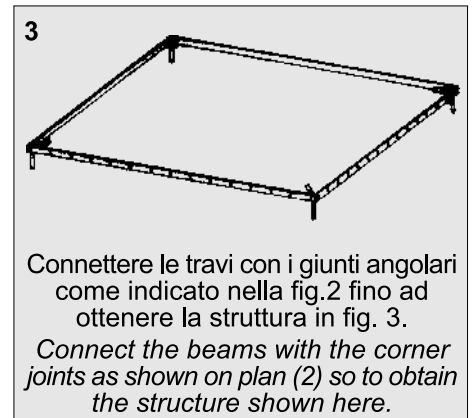
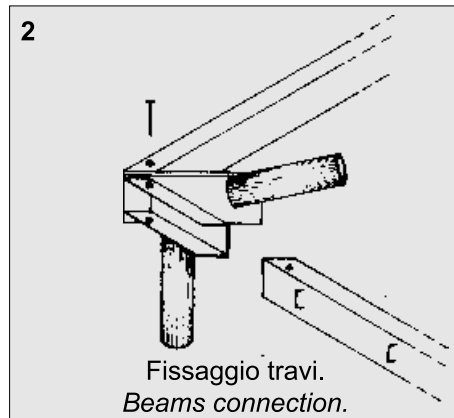
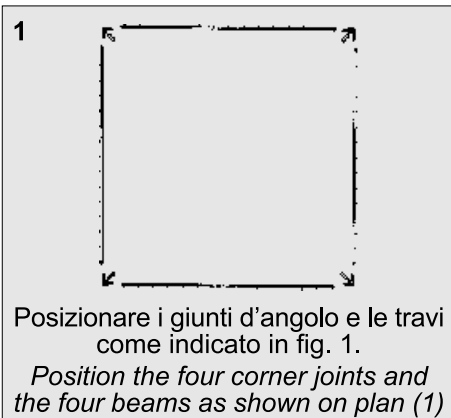

Optionals mod. Airone (in acciaio zincato / galvanized steel)

GRONDA in PVC ignifugo Fire-retardant PVC GUTTER

Lato Side	Massima lunghezza maximal metrical	m^3	Kg	n° colli # pieces
m 3.00	0.8	0.01	1.3	1
m 4.00	0.8	0.01	1.8	1
m 4.90	0.8	0.01	2.2	1
m 6.00	0.8	0.01	2.7	1

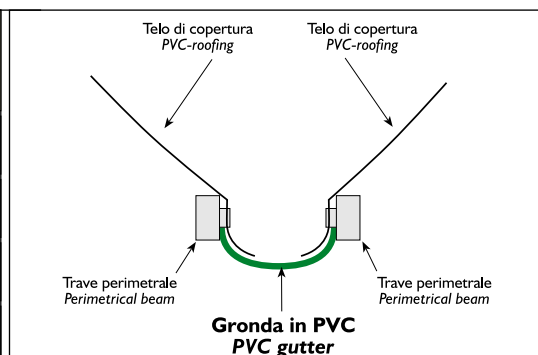

GRONDA in acciaio zincato galvanized steel GUTTER

Lato Side	Massima lunghezza maximal metrical	m^3	Kg	n° colli # pieces
m 3.00	3.09	0.05	11	1
m 4.00	4.09	0.06	15	1
m 4.90	4.99	0.07	18	1
m 6.00	6.09	0.08	25	1

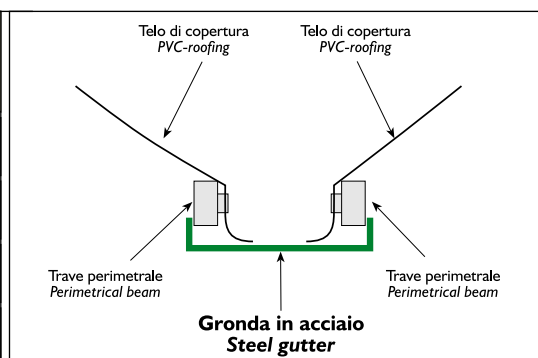

LATERALE FISSO in PVC ignifugo / Fire-retardant PVC FIXED LATERAL

Lato Side	Massima lunghezza Maximal metrical	m^3	Kg	n° colli # pieces
m 3.00	3.04	0.08	10	2
m 4.00	4.04	0.08	14	2
m 4.90	4.94	0.08	16	2
m 6.00	6.04	0.08	20	2

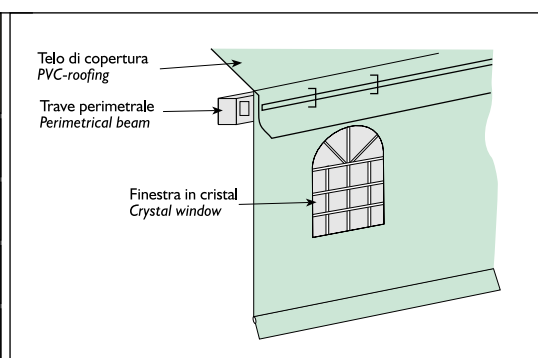

LATERALE SCORREVOLE in PVC ignifugo / Fire-retardant PVC SLIDING LATERAL

Lato Side	Massima lunghezza Maximal metrical	m^3	Kg	n° colli # pieces
m 3.00	3.00	0.08	8	2
m 4.00	4.00	0.08	11	2
m 4.90	4.90	0.08	14	2
m 6.00	6.00	0.08	18	2

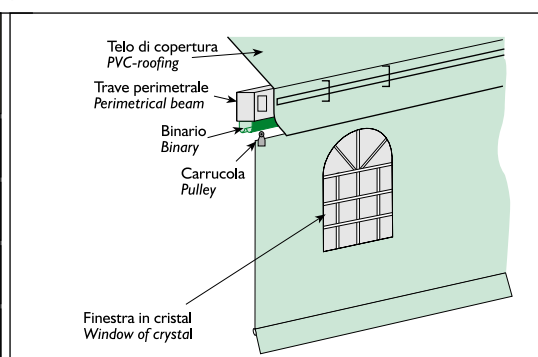



modello **Pagoda** "New"





Sezione dei profili utilizzati per il modello Pagoda "New" Section of the utilized profiles for the model "New" Pagoda

Sezione del montante
Section of the vertical pillar

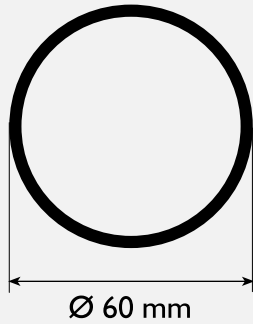

Sezione della barra perimetrale
Section of the perimetrial beam

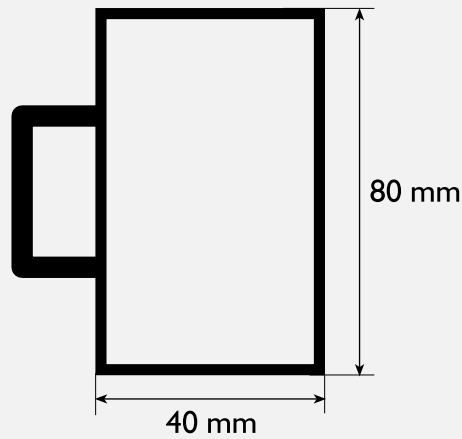

Sezione del puntone inclinato
Section of the inclined bar

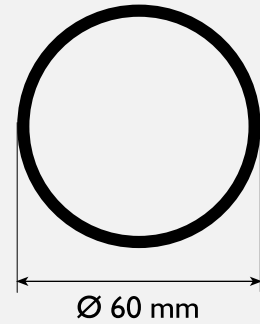

Componenti principali della struttura Principal elements of the structure



Calotta a stella
Inclined rafter blocker

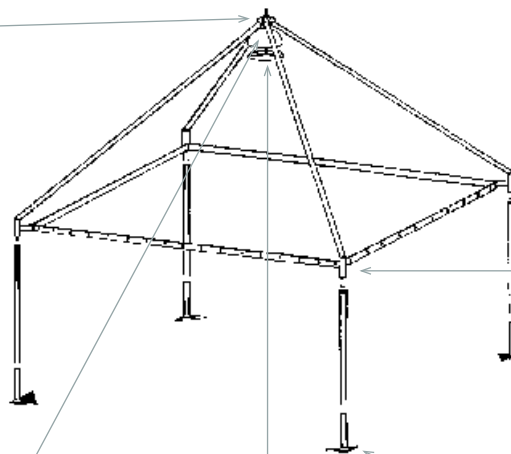

Innesto angolare
Angular joint



Cupolino coprisfiato
Air-outlet top-cup



Piatto tenditelo
Threaded-bar





Piede
Foot

mod. Pagoda "New" (in acciaio zincato / galvanized steel)



con struttura in acciaio zincato o zincato-verniciato*, telo di copertura in PVC ignifugo e cupolino coprisfiato modello I.
with galvanized steel frame or powder coated galvanized steel frame, fire-retardant PVC cover and air-outlet top cup type I.

PAGODA quadrata / Squared PAGODA

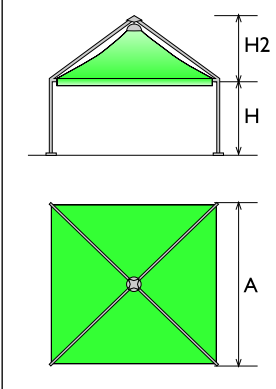
A	H	H2	 $\simeq m^2$	Massima lunghezza maximal metrical	 $\simeq m^3$	 $\simeq Kg$	n° colli # pieces
m 3.30	2.18	1.45	9.00	2.98	0.27	132	8
m 4.30	2.18	1.80	16.00	3.98	0.29	170	8
m 5.20	2.18	2.12	24.00	4.88	0.30	197	8
m 6.30	2.18	2.40	36.00	5.98	0.34	317	12



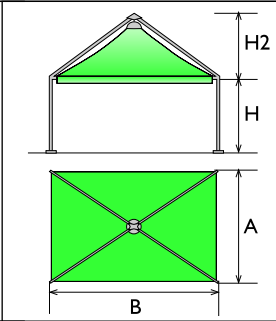

PAGODA rettangolare / rectangular PAGODA

A - B	H	H2	 $\simeq m^2$	Massima lunghezza maximal metrical	 $\simeq m^3$	 $\simeq Kg$	n° colli # pieces
m 3.30 x m 4.30	2.18	1.70	12.00	3.98	0.30	150	8
m 4.30 x m 5.20	2.18	2.10	19.60	4.88	0.32	185	8
m 5.20 x m 6.30	2.18	2.50	29.40	5.98	0.33	270	10



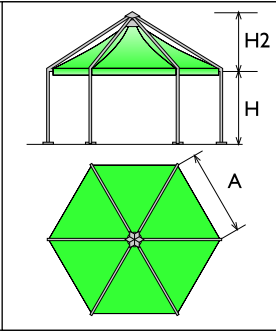

Pagoda esagonale / hexagonal Pagoda

A	H	H2	 $\simeq m^2$	Massima lunghezza maximal metrical	 $\simeq m^3$	 $\simeq Kg$	n° colli # pieces
m 3.30	2.18	1.70	23.38	3.26	0.31	225	11
m 4.30	2.18	2.20	43.67	4.47	0.34	288	11
m 5.20	2.18	2.70	62.38	5.40	0.37	338	11



PAGODA ottagonale / octagonal PAGODA

A	H	H2	 $\simeq m^2$	Massima lunghezza maximal metrical	 $\simeq m^3$	 $\simeq Kg$	n° colli # pieces
m 3.30	2.18	1.90	43.45	4.10	0.39	291	15
m 4.30	2.18	2.70	81.16	5.75	0.44	369	15

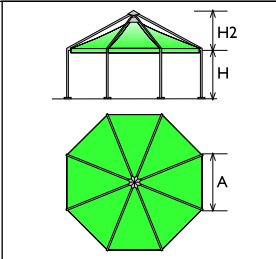

Schema di montaggio del modello Pagoda "New"

Assembling plan for the model "New" Pagoda

1



Posizionare i giunti d'angolo e le travi come indicato in fig. 1.
Position the four corner joints and the four beams as shown on plan(1).

2

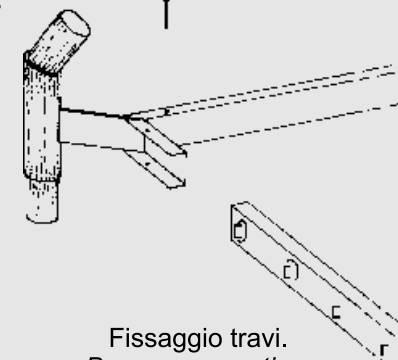

Fissaggio travi.
Beams connection.

3

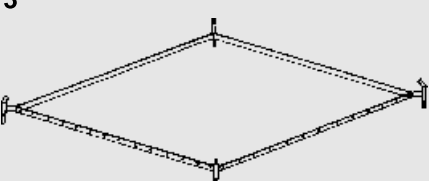

Connettere le travi con i giunti angolari come indicato nella fig.2 fino ad ottenere la struttura in fig. 3.
Connect the beams with the corner joints as shown on plan (2) so to obtain the structure as on plan (3)

4

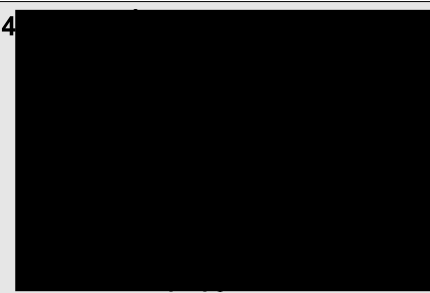

Inserire i puntoni iclinati sugli appositi innesti situati agli angoli.
Insert beams on proper tubes located on each corner.

5

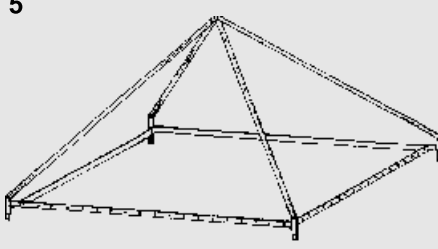

Fissare i puntoni iclinati ai giunti d'angolo ottenendo la struttura in fig.5
Fix the inclined bars to the corner joints so to obtain the structure as shown on plan (5)

6

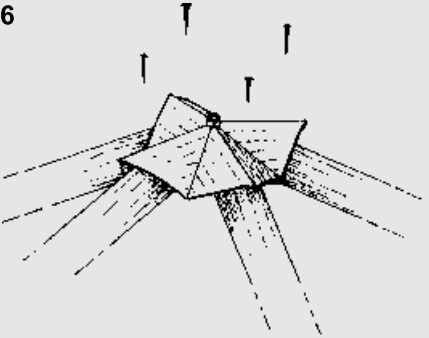

Posizionare l'innesto centrale di colmo.
Block rafters apex.

7



Inserire il piatto tenditelo all'interno del telo di copertura e fissare il cupolino coprisfiato all'esterno.
Position lifting plate underneath PVC and set top-cup over it.

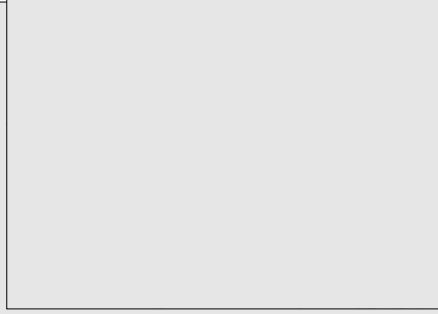

Abboccare l'asta filettata all'innesto centrale in modo da appendere il telo.
Screw threaded rod into top hole.



10



Posizionare il telo e bloccarlo per mezzo della cinghia alle travi perimetrali.
Properly position perimetrically the pvc cover and fix it against the beam, as show on plan (10)

11

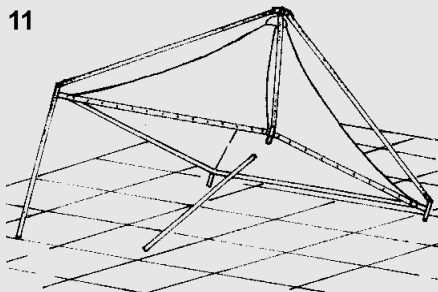

Sollevare la struttura facendola ruotare su di un lato e inserire i due montanti
Rise the structure rotating it on one side so to insert its columns

12

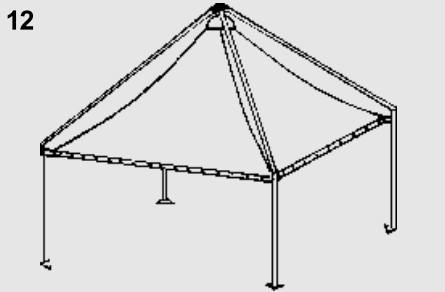

Completare la struttura e mettere in tensione il telo agendo sull'asta filettata
Once the structure is completed, rotate the screw-bar to tension the pvc roofing

Optionals mod. Pagoda "New" (in acciaio zincato / galvanized steel)

GRONDA in PVC ignifugo *Fire-retardant PVC GUTTER*

Lato Side	Massima lunghezza maximal metrical	$\simeq m^3$	$\simeq Kg$	n° colli # pieces
m 3.30	0.8	0.01	1.3	1
m 4.30	0.8	0.01	1.8	1
m 5.20	0.8	0.01	2.2	1
m 6.30	0.8	0.01	2.7	1

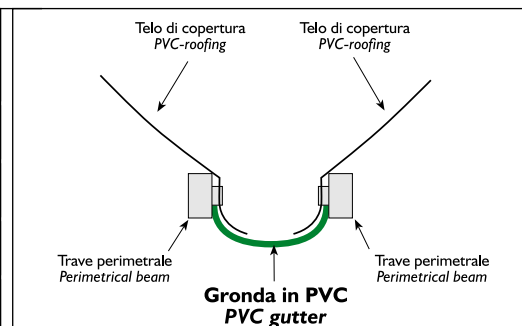

GRONDA in acciaio zincato *galvanized steel GUTTER*

Lato Side	Massima lunghezza maximal metrical	$\simeq m^3$	$\simeq Kg$	n° colli # pieces
m 3.30	2.74	0.11	17	1
m 4.30	3.74	0.14	24	1
m 5.20	4.64	0.18	28	1
m 6.30	5.74	0.22	37	1

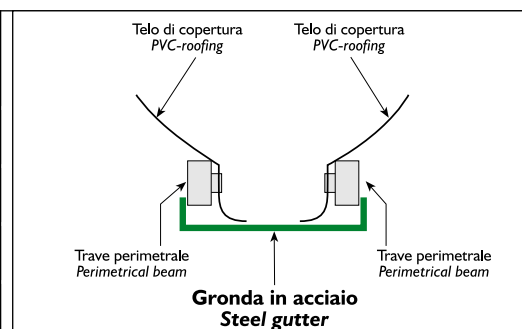

GIUNTO CENTRALE GRONDAIE in acciaio zincato / *GUTTERS CENTRAL JUNCTION galvanized steel*

$\simeq m^3$	$\simeq Kg$	n° colli # pieces
0.01	2	1

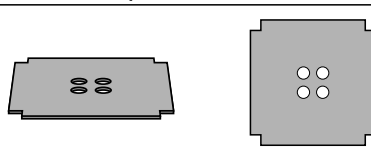

LATERALE FISSO in PVC ignifugo / *Fire-retardant PVC FIXED LATERAL*

Lato Side	Massima lunghezza maximal metrical	$\simeq m^3$	$\simeq Kg$	n° colli # pieces
m 3.30	2.74	0.08	10	2
m 4.30	3.84	0.08	14	2
m 5.20	4.64	0.08	16	2
m 6.30	5.74	0.08	20	2

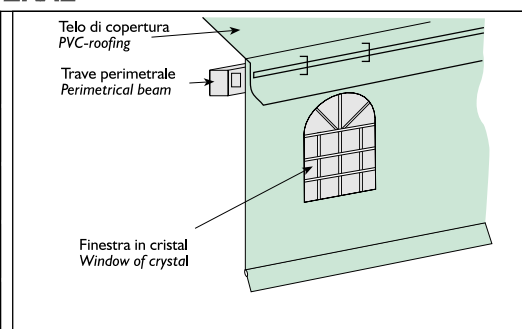

LATERALE SCORREVOLE in PVC ignifugo / *Fire-retardant PVC SLIDING LATERAL*

Lato Side	Massima lunghezza maximal metrical	$\simeq m^3$	$\simeq Kg$	n° colli # pieces
m 3.30	2.74	0.08	8	2
m 4.30	3.84	0.08	11	2
m 5.20	4.64	0.08	14	2
m 6.30	5.74	0.08	18	2

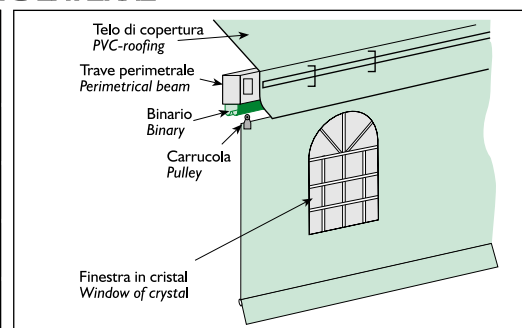



modello **Pagoda**
"Classic"



Sezione dei profili utilizzati per il modello Pagoda "Classic" Section of the utilized profiles for the model "Classic" Pagoda

Sezione del montante
Section of the vertical pillar

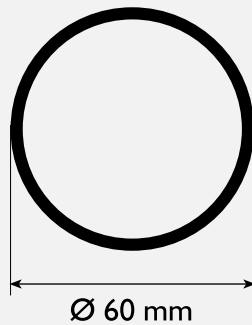

Sezione della barra perimetrale
Section of the perimetrial beam

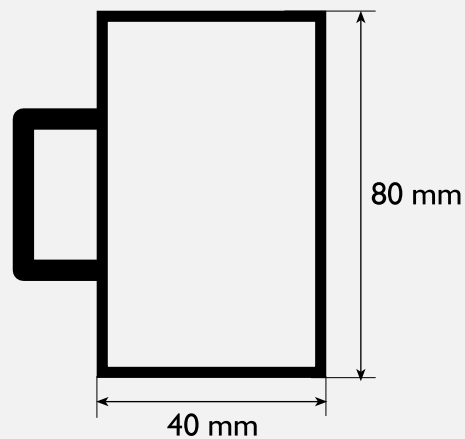

Sezione del puntone inclinato
Section of the inclined bar

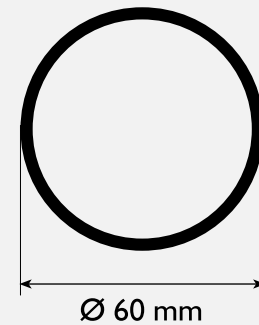

Componenti principali della struttura Principal elements of the structure



Calotta a stella
Inclined rafter blocker

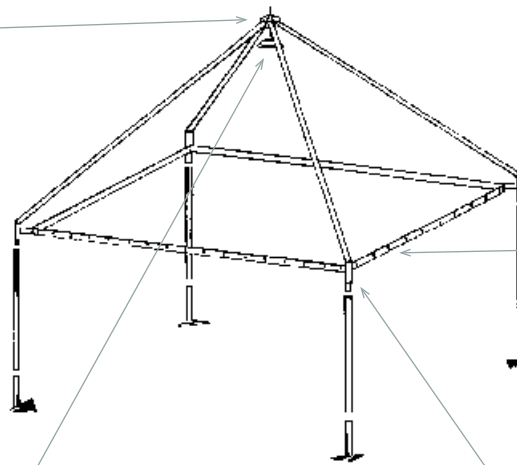

Trave perimetrale
Perietrical beam



Assieme tenditelo
Threaded-bar



Piede
Foot





Innesto angolare
Angular joint

mod. Pagoda "Classic" (in acciaio zincato / galvanized steel)

con struttura in acciaio zincato o zincato-verniciato* e telo di copertura in PVC ignifugo.



with galvanized steel frame or powder coated galvanized steel frame and fire-retardant PVC cover.

PAGODA quadrata / squared PAGODA

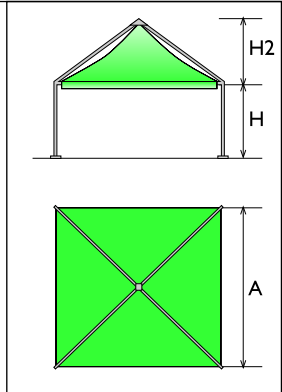
A	H	H2	 $\leq m^2$	Massima lunghezza maximal metrical	 $\leq m^3$	 $\leq Kg$	n° colli # pieces
m 3.00	2.18	1.50	7.30	2.70	0.27	132	8
m 4.10	2.18	1.90	14.44	3.80	0.29	170	8
m 4.90	2.18	2.40	21.16	4.60	0.30	197	8
m 6.00	2.18	2.90	32.50	5.70	0.34	317	12



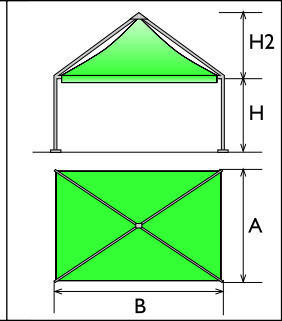

PAGODA rettangolare / rectangular PAGODA

A - B	H	H2	 $\leq m^2$	Massima lunghezza maximal metrical	 $\leq m^3$	 $\leq Kg$	n° colli # pieces
m 3.00 x m 4.10	2.18	1.63	10.26	3.80	0.30	150	8
m 4.10 x m 4.90	2.18	2.00	17.50	4.60	0.32	185	8
m 4.90 x m 6.00	2.18	2.40	26.20	5.70	0.33	270	10



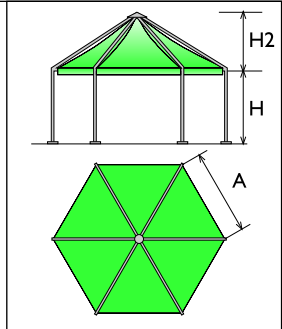

PAGODA esagonale / hexagonal PAGODA

A	H	H2	 $\leq m^2$	Massima lunghezza maximal metrical	 $\leq m^3$	 $\leq Kg$	n° colli # pieces
m 3.00	2.18	1.70	18.94	3.26	0.31	225	11
m 4.10	2.18	2.20	37.50	4.47	0.34	288	11
m 4.90	2.18	2.70	55.00	5.40	0.37	338	11



PAGODA ottagonale / octagonal PAGODA

A	H	H2	 $\leq m^2$	Massima lunghezza maximal metrical	 $\leq m^3$	 $\leq Kg$	n° colli # pieces
m 3.00	2.18	1.90	35.20	4.10	0.39	291	15
m 4.10	2.18	2.70	69.70	5.75	0.44	369	15

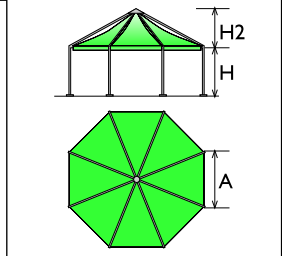

Schema di montaggio del modello Pagoda "Classic"

Assembling plan for the model "Classic" Pagoda

1

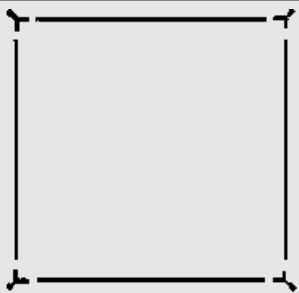

Posizionare i giunti d'angolo e le travi come indicato in fig. 1.
Position the four corner joints and the four beams as shown on plan (1).

2

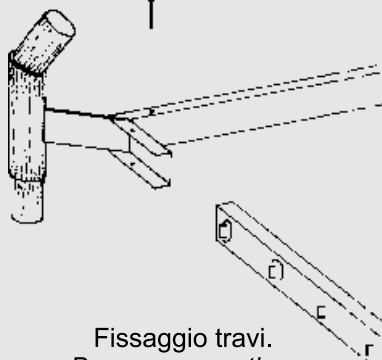

Fissaggio travi.
Beams connection.

3

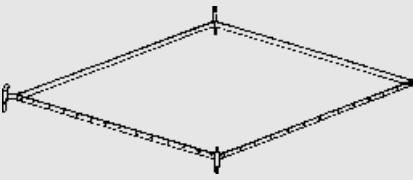

Connettere le travi con i giunti angolari come indicato nella fig.2 fino ad ottenere la struttura in fig. 3.
Connect the beams with the corner joints as shown on plan (2) so to obtain the structure as on plan (3)

4



Inserire i puntoni sugli appositi innesti situati agli angoli.
Insert beams on proper tubes located on each corner.

5

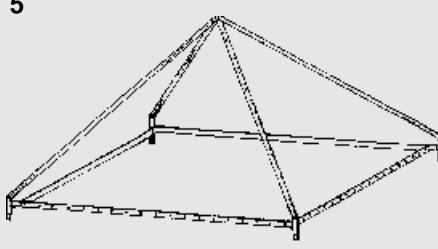

Fissare i puntoni ai giunti d'angolo ottenendo la struttura in fig.5
Fix the inclined bars to the corner joints so to obtain the structure as shown on plan (5)

6

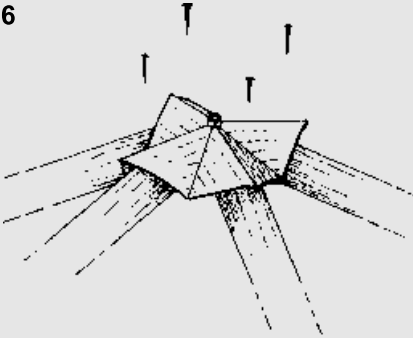

Posizionare l'innesto centrale di colmo
Block rafters apex

7



Inserire il supporto spingitelo dall'interno del telo di copertura.
Block pvc between two plates.

Abboccare l'asta filettata all'innesto centrale in modo da appendere il telo.
Screw threaded rod into top hole.



Posizionare il telo e bloccarlo per mezzo della cinghia alle travi perimetrali.
Properly position perimetrically the pvc cover and fix it against the beam, as show on plan (10)

11

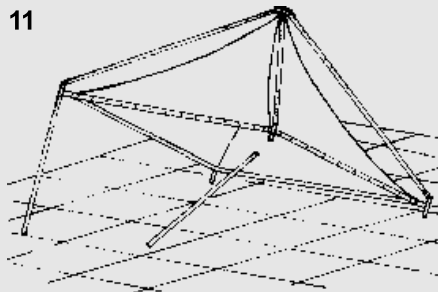

Sollevare la struttura facendola ruotare su di un lato e inserire i due montanti
Rise the structure rotating it on one side so to insert its columns

12

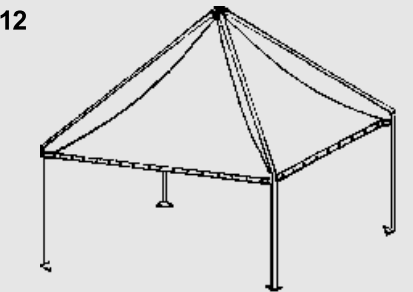

Completare la struttura e mettere in tensione il telo agendo sull'asta filettata
Once the structure is completed, rotate the screw-bar to tension the pvc roofing

Optionals mod. Pagoda "Classic" (in acciaio zincato / galvanized steel)

GRONDA in PVC ignifugo *Fire-retardant PVC GUTTER*

Misura lato <i>Side measure</i>	Massima lunghezza <i>Maximal metrical</i>	$\simeq m^3$	$\simeq Kg$	n° colli <i># pieces</i>
m 3.00	0.8	0.01	1.3	1
m 4.10	0.8	0.01	1.8	1
m 4.90	0.8	0.01	2.2	1
m 6.00	0.8	0.01	2.7	1

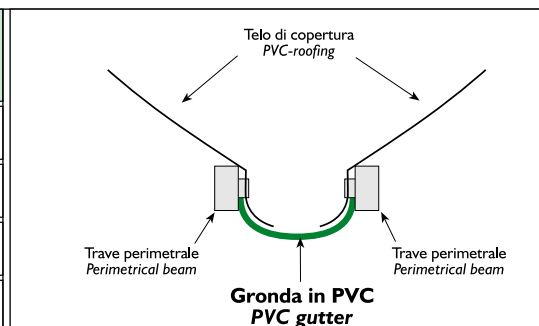

GRONDA in acciaio zincato *galvanized steel GUTTER*

Lato <i>Side</i>	Massima lunghezza <i>maximal metrical</i>	$\simeq m^3$	$\simeq Kg$	n° colli <i># pieces</i>
m 3.00	2.74	0.11	17	1
m 4.10	3.74	0.14	24	1
m 4.90	4.64	0.18	28	1
m 6.00	5.74	0.22	37	1

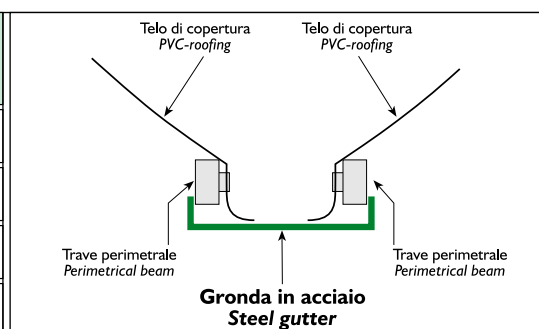

GIUNTO CENTRALE GRONDAIE in acciaio zincato / *GUTTERS CENTRAL JUNCTION galvanized steel*

$\simeq m^3$	$\simeq Kg$	n° colli <i># pieces</i>
0.01	2	1

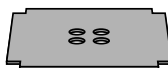

LATERALE FISSO in PVC ignifugo / *Fire-retardant PVC FIXED LATERAL*

Lato <i>Side</i>	Massima lunghezza <i>maximal metrical</i>	$\simeq m^3$	$\simeq Kg$	n° colli <i># pieces</i>
m 3.00	2.74	0.08	10	2
m 4.10	3.84	0.08	14	2
m 4.90	4.64	0.08	16	2
m 6.00	5.74	0.08	20	2

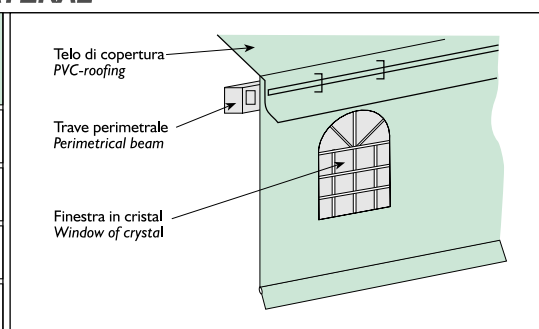

LATERALE SCORREVOLE in PVC ignifugo / *Fire-retardant PVC SLIDING LATERAL*

Lato <i>Side</i>	Massima lunghezza <i>maximal metrical</i>	$\simeq m^3$	$\simeq Kg$	n° colli <i># pieces</i>
m 3.00	2.74	0.08	8	2
m 4.10	3.84	0.08	11	2
m 4.90	4.64	0.08	14	2
m 6.00	5.74	0.08	18	2

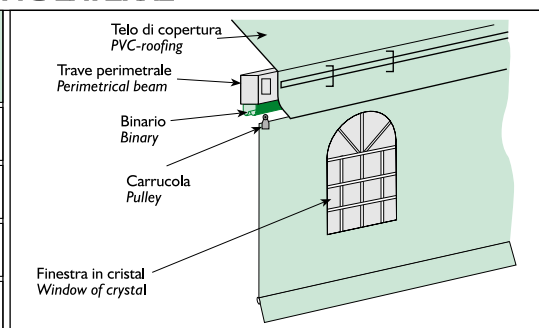

Altri accessori (per il modello Airone, Pagoda "New" e Pagoda "Classic")

Additional accessories (for model Airone, Pagoda "New" and Pagoda "Classic")

COPRIPIANTONE in PVC ignifugo <i>Pillar's PVC cover</i>		
Modello Type	A	H
1	0.45	2.30

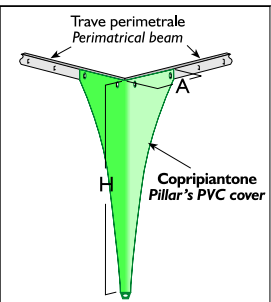
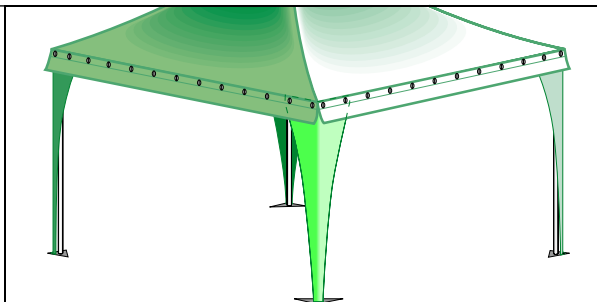

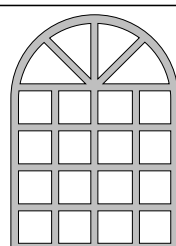
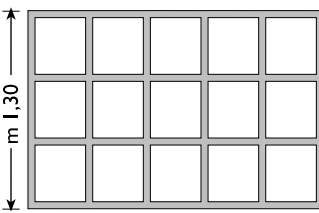
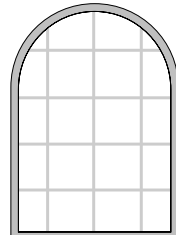
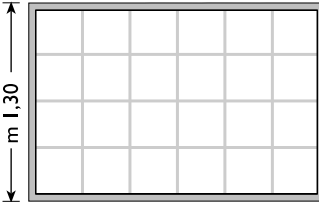

FINERSTRA in cristal / Crystal-PVC WINDOW



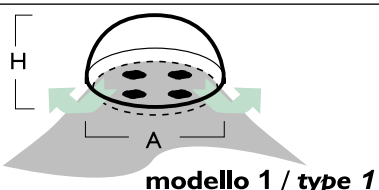

Finestra modello 1 / window model 1		Finestra modello 2 / window model 2	
	Finestra in cristal saldata Dimensione: m 1.00 x 1.50 <i>Welded PVC crystal window</i> Measuring: m 1.00 x 1.50		Finestra in cristal saldata Dim.: m 1.30 x lunghezza richiesta <i>Welded PVC crystal window</i> Measuring: m 1.30 x desired length
Finestra modello 3 / window model 3		Finestra modello 4 / window model 4	
	Finestra in cristal serigrafata Dimensione: m 1.00 x 1.50 <i>Serigraphed PVC crystal window</i> Measuring: m 1.00 x 1.50		Finestra in cristal serigrafata Dim.: m 1.30 x Lunghezza richiesta <i>Serigraphed PVC crystal window</i> Measuring: m 1.30 x desired length

CUPOLINO COPRISIATO / AIR-OUTLET TOP-CUP

Cupolino coprisiato / Air-outlet top-cup			
Modello Type	codice / code	A	H
I	SAICUP_1	34	17



MANTOVANA in PVC ignifugo / fire retardant PVC VALANCE

				
--	---	---	--	---

Colori disponibili per la passamaneria: panna (standard), bianco, nero, rosso, verde, blu, giallo, marrone, grigio
Colours available for the trimmings: cream (standard), white, black, red, green, blue, yellow, brown, grey

Colori base struttura
Powder-coating
colours available

PVC Poly 650

RAL 9010 SL (standard)		RAL 9010 white
-----		Avory 205
-----		Beige 226
RAL 1014 SL		RAL 1014 Beige
RAL 1013 SL		RAL 1013 Beige
RAL 1003 SL		RAL 1003 yellow
RAL 1021 SL		RAL 1021 yellow
RAL 2011 SL		RAL 2011 orange
RAL 3000 SL		RAL 3000 red
RAL 3011 SL		RAL 3011 dark red
RAL 5015 SL		RAL 5015 light blue
RAL 5010 SL		RAL 5002 blue
RAL 6001 SL		RAL 6001 light green
RAL 6016 SL		RAL 6016 green
RAL 6026 SL		RAL 6026 dark green
RAL 7035 SL		RAL 7035 grey
RAL 7038 SL		RAL 7038 grey
RAL 7037 SL		RAL 7037 grey
RAL 8017 SL		-----
RAL 9005 SL		-----