

1

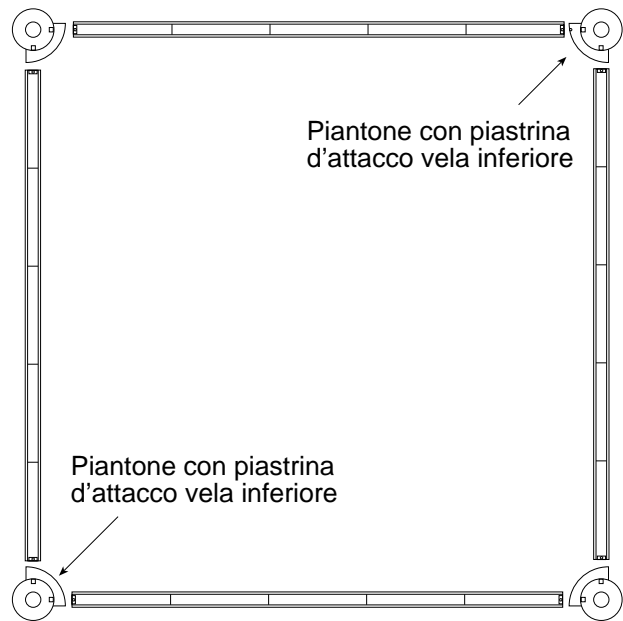

Posizionare i piantoni e le travi come indicato in figura 1

2

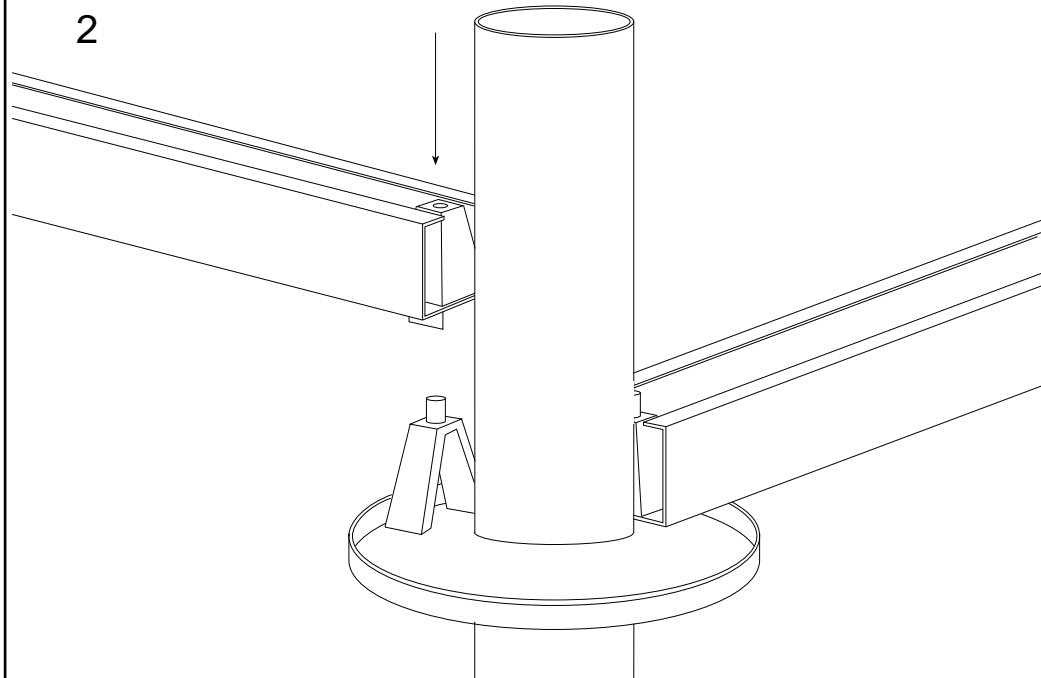

3

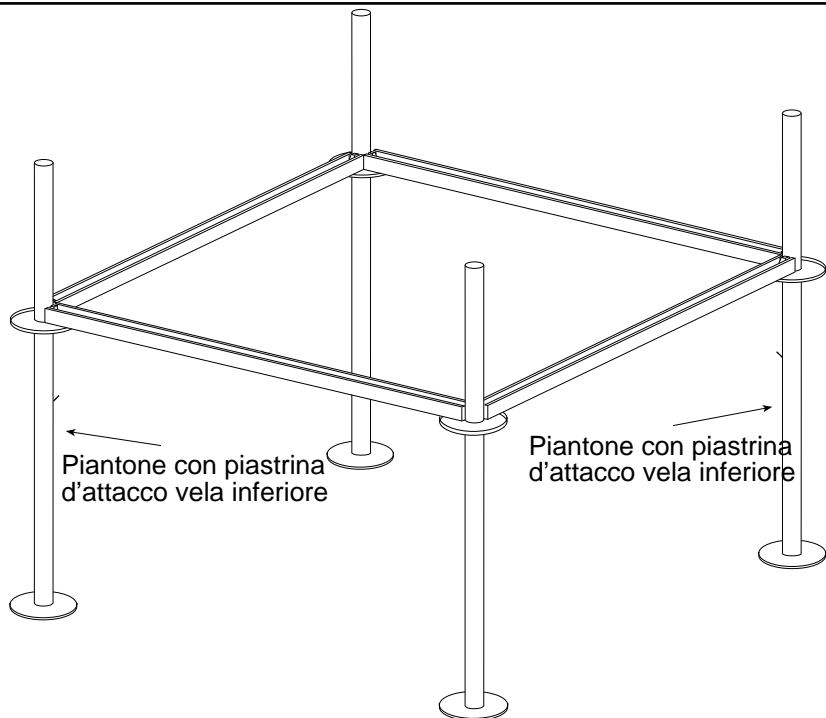

4

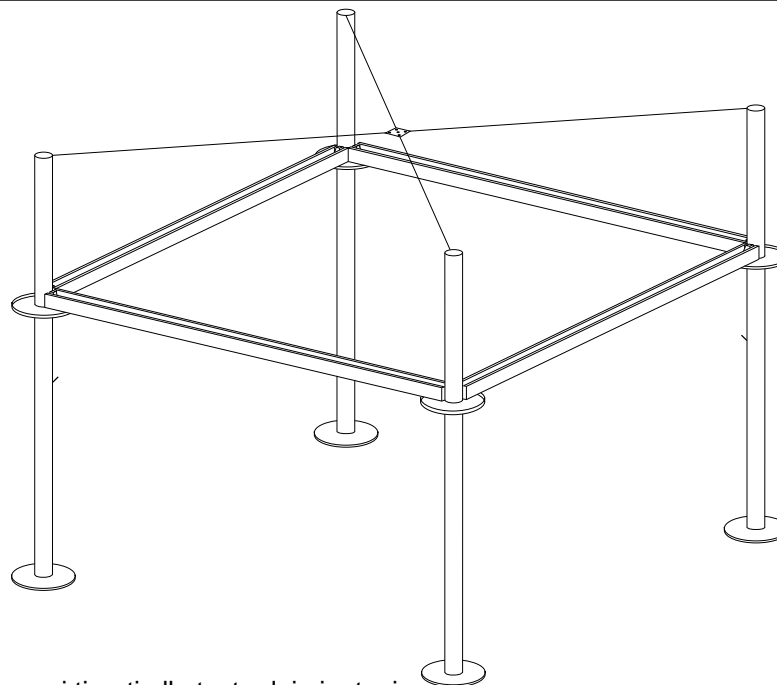

Collegare i tiranti alla testa dei piantoni

5

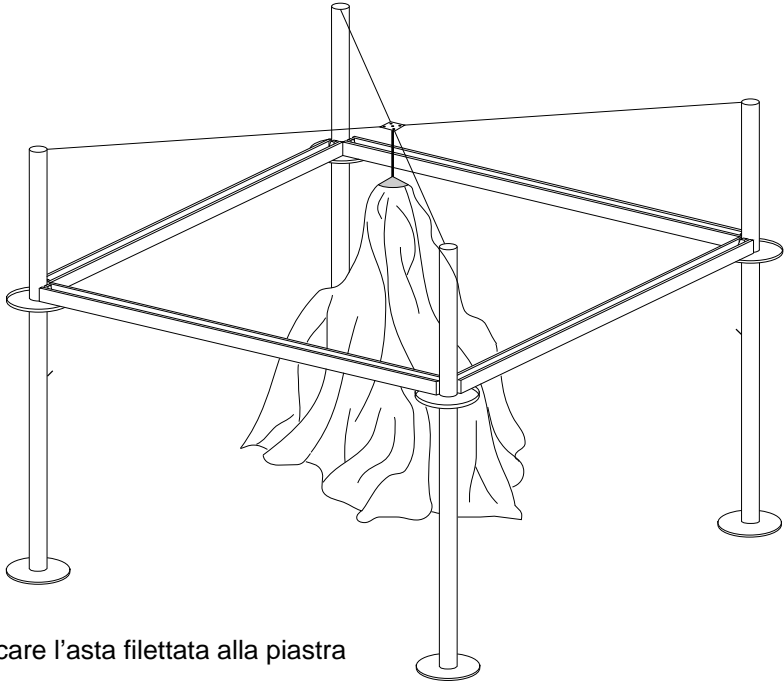

Abboccare l'asta filettata alla piastra

6

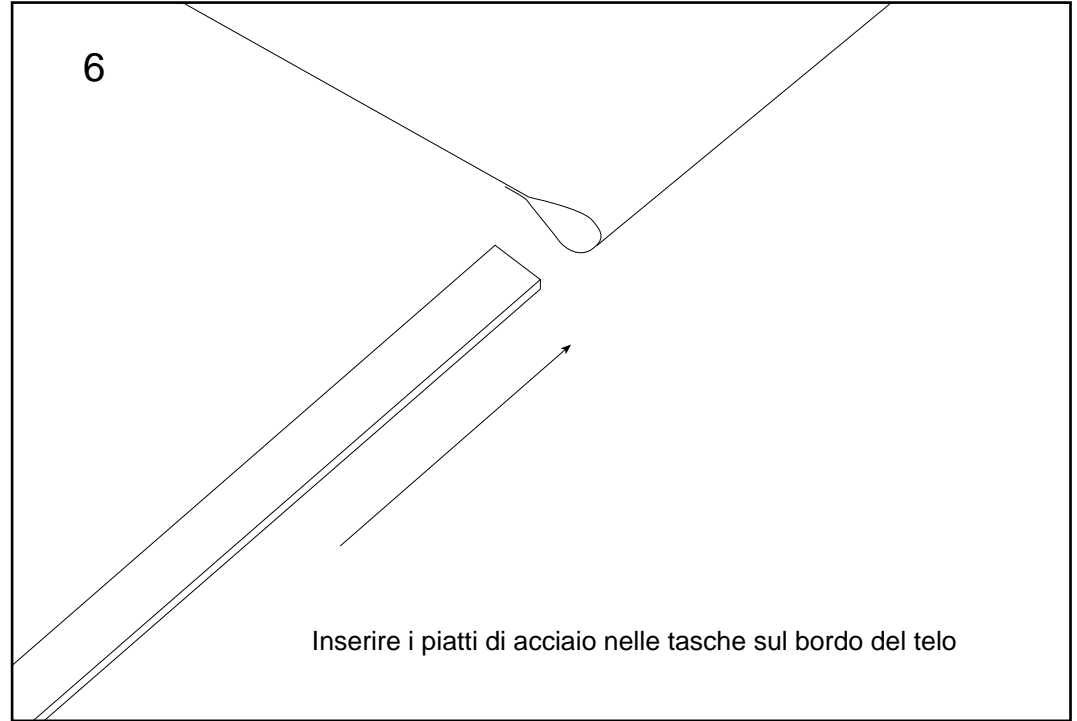

Inserire i piatti di acciaio nelle tasche sul bordo del telo

7

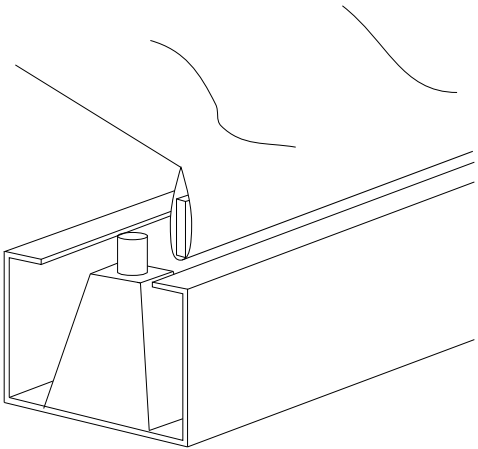

Agganciare il telo sotto l'aletta da cm 3 della trave perimetrale

SEZIONE DELLA TRAVE PERIMETRALE

Telo di copertura

A

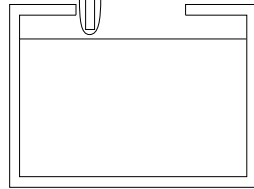

Telo di copertura

B

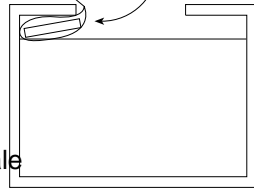

8

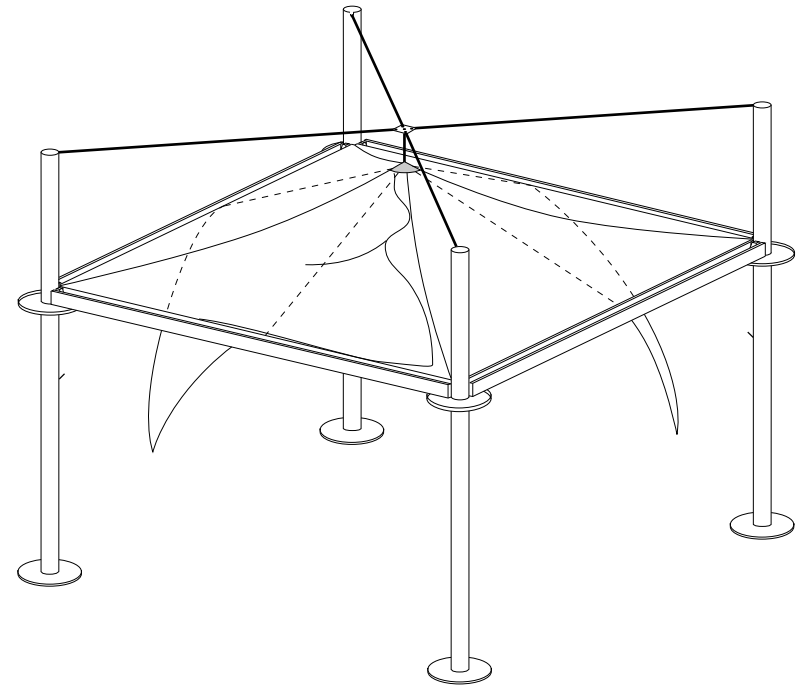

9

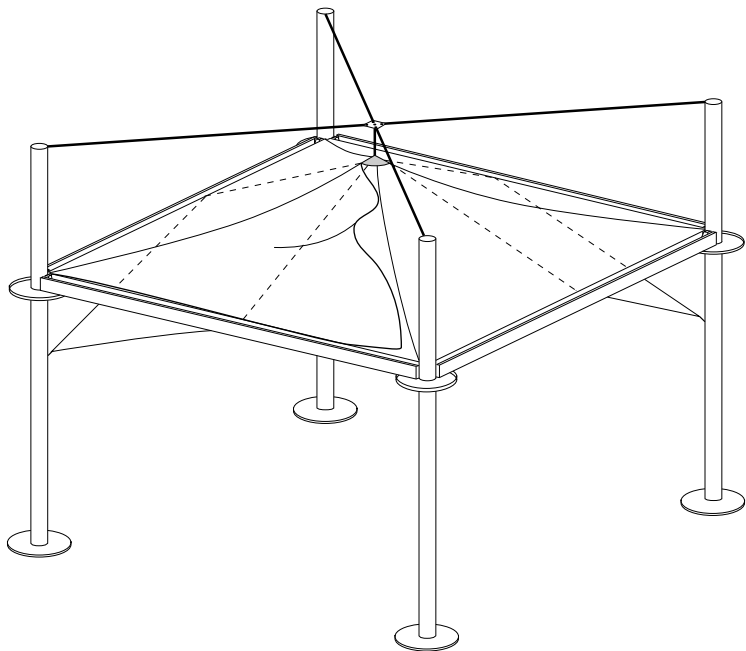

Agganciare le vele inferiori alle piastrine presenti sui due piantoni opposti in diagonale

10

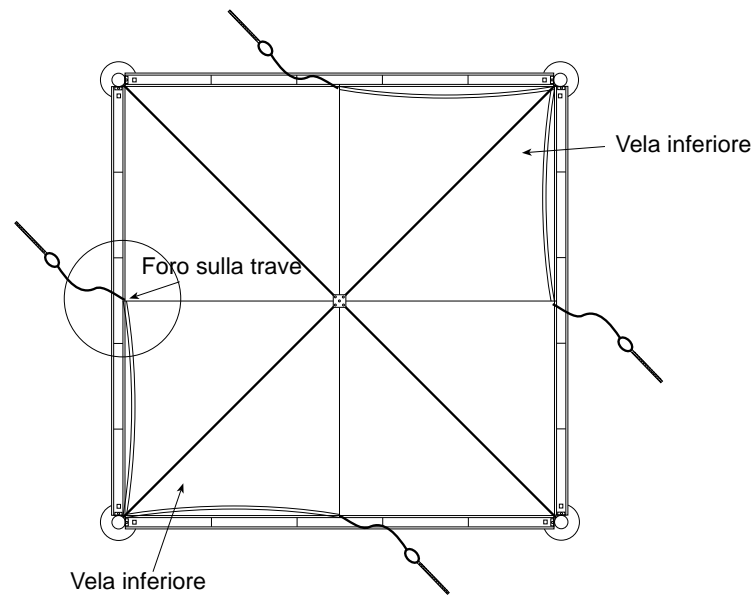

Infilare il cavo d'acciaio nell'apposito foro predisposto al centro di ogni trave perimetrale facendo attenzione che le due estremità siano uguali

11

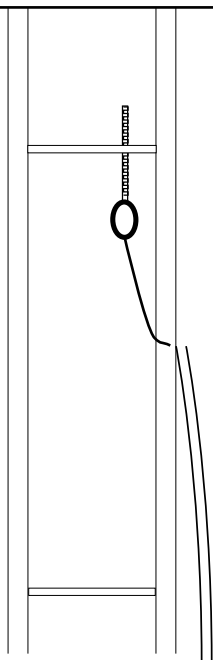

Infilare il tenditore nell'apposito foro predisposto all'interno della trave.

12

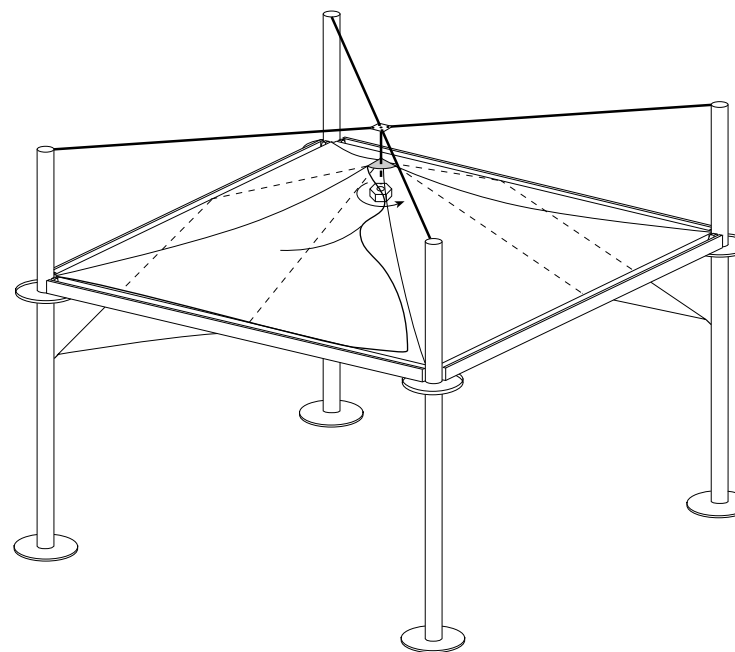

Mettere in tensione il telo agendo sull'asta filettata all'interno del modulo

13

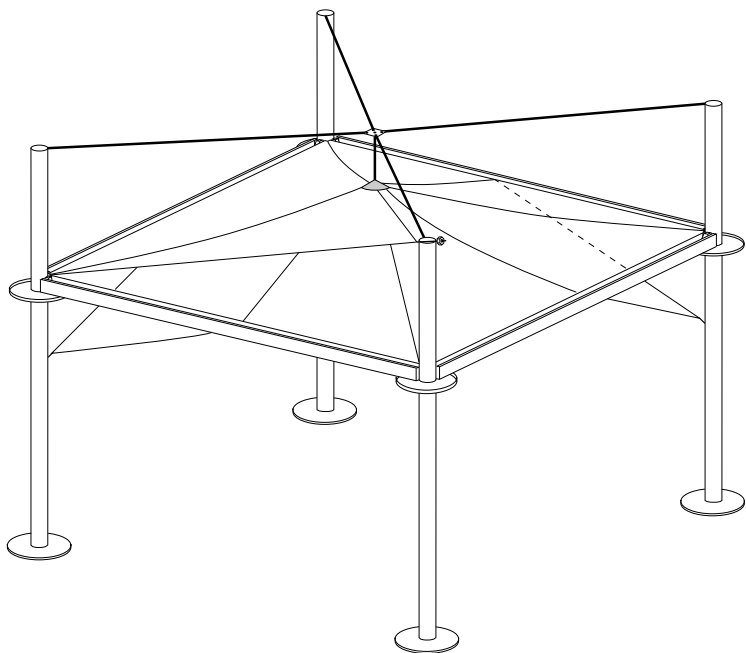

Infilare il tenditore della vela superiore nell'apposito foro predisposto sulla cima del pianone.

14

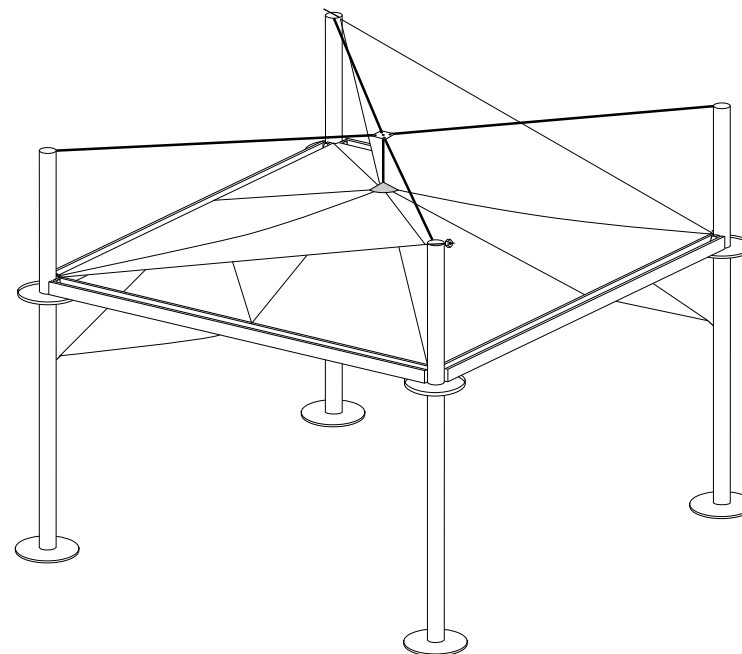

Ripetere l'ultima operazione per la vela superiore opposta

SCHEMA DE MONTAJ PENTRU

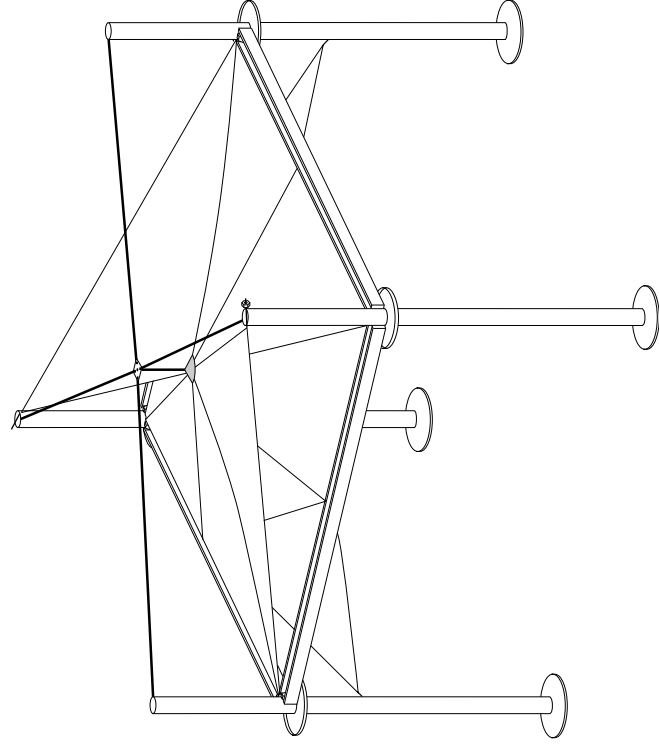

MODELUL ALBATROS